

APPLY HEAT TO FLASHING  
AND FORM BY HAND PRIOR  
TO HOT AIR WELDING

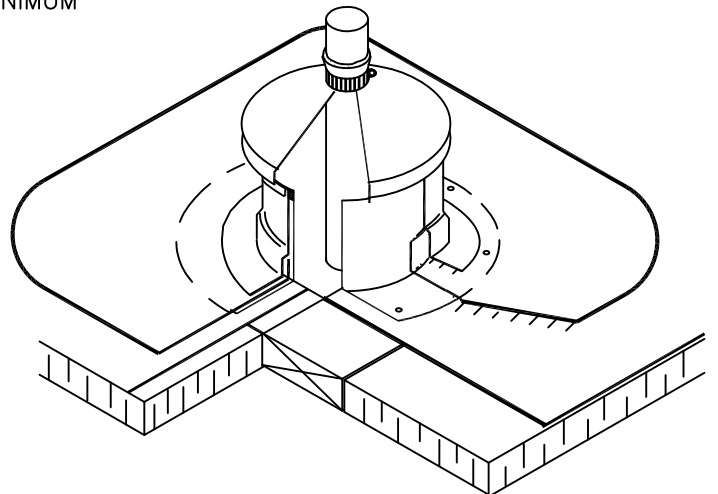

NOTES:

1. FIELD-FABRICATED PIPE SEAL FOR USE WITH HOT PIPE, 120° F (49° C) OR HOTTER.
2. FLEX NON-REINFORCED MEMBRANE WRAPPED AROUND PIPE SHALL HAVE MINIMUM 1-1/2" (40 mm) VERTICAL HOT AIR WELD.
3. TEMPERATURE OF METAL COLLAR MUST NOT EXCEED 120° F.

TITLE	
HOT PIPE FLASHING	
NAME	
DETAIL NO. 4.50	
DRAWN BY:	DATE:
SK	8/2012
APPLICABLE TO ALL FLEX TPO	
MECHANICALLY FASTENED SYSTEMS	
FLEX MEMBRANE INTERNATIONAL	2670 LEISCZS BRIDGE RD. LEESPORT, PA 19533 800-969-0108 FlexRoofingSystems.com